

MIL-B-5087B(ASG)
15 OCTOBER 1964

Superseding
MIL-B-5087A(ASG)
30 July 1954

MILITARY SPECIFICATION

BONDING, ELECTRICAL, AND LIGHTNING PROTECTION, FOR AEROSPACE SYSTEMS

This specification has been approved by the Department of the Air Force and by the Bureau of Naval Weapons.

1. SCOPE

1.1 Scope.- This specification covers the characteristics, application, and testing of electrical bonding (see 6.2.2) for aerospace systems, as well as bonding for the installation and interconnection of electrical and electronic equipment therein, and lightning protection.

1.2 Classification.- Electrical bonds are classified as specified in table i (see 3.2).

2. APPLICABLE DOCUMENTS

2.1 The following documents, of the issue in effect on date of invitation for bids or request for proposal, form a part of this specification to the extent specified herein:

SPECIFICATIONS

Military

MIL-L-6806 Lacquer, Clear, Aluminum Clad Aluminum Alloy Surfaces

STANDARDS

Military

MIL-STD-143 Specifications and Standards, Order of Precedence
for the Selection of
MS25083 Jumper Assembly, Electric, Bonding and Current Return
MS33586 Metals, Definition of Dissimilar
MS35337 Washer, Lock, Split, Helical, Light Series
MS35339 Washer, Lock, Split, Helical, Heavy Series

FSC 6150

Air Force-Navy Aeronautical

AN526	Screw, Machine, Truss Head
AN735	Clamp, Loop Type Bonding
AN742	Clamp, Plain, Support, Loop-Type, Aircraft
AN935	Washer - Lock, Spring
AN960	Washer, Flat

(Copies of specifications, standards, drawings, and publications required by suppliers in connection with specific procurement functions should be obtained from the procuring activity or as directed by the contracting officer.)

2.2 Other publications.- The following documents form a part of this specification to the extent specified herein. Unless otherwise indicated, the issue in effect on date of invitation for bids or request for proposal shall apply.

National Aerospace Standards

NAS679	Nut, Self-Locking, Hexagonal, Low Height, 550° F, 800° F
NAS680	Nut, Self-Locking, Plate, Two Lug, C Bored, Low Height, 550° F, 800° F

(Application for copies should be addressed to Aerospace Industries Association of America, Inc., 1725 DeSales Street, N.W., Washington, D. C. 20036.)

3. REQUIREMENTS

3.1 Materials and parts.- Materials and parts shall be as specified herein.

3.1.1 Selection of materials.- Specifications and standards for all materials and parts and Government certification and approval of processes and equipment not specifically designated herein which are necessary for the execution of this specification, shall be selected in accordance with MIL-STD-143, except as provided in 3.1.1.1.

3.1.1.1 Standard parts.- Standard parts (MS, AN, or JAN) shall be used wherever suitable for the purpose intended, and shall be identified on drawings or in other documents by their part numbers. Commercial standard parts, such as screws, bolts, washers, nuts, and other cotter pins may be used, provided they do not have a degrading effect on the equipment during, or after environmental tests specified in the detail equipment specification (see 6.2.6) and are replaceable with the standard parts (MS, AN, or JAN) without alteration. A cross-reference of government standard part numbers shall be shown with the corresponding commercial part numbers on the parts list and the contractor's drawings.

3.1.1.1.1 Hardware usage.- The following data shall be used in selecting hardware for bonding purposes:

(a) Bolts, nuts and screws:

Cadmium plated steel (for ground use only)	Use when weight is not critical. Not recommended above 550° F due to sublimation of cadmium.
Corrosion-resistant steel	High temperature application.
Titanium	High temperature and weight savings. (Do not use tetrafluoro-ethylene-coated bolts when bolt must carry current).
Aluminum	General usage at temperatures up to 300° F.
Self-tapping screws	Prohibited.
Zinc plated	Prohibited.

(b) Washers:

Anodised	Prohibited.
Zinc plated	Prohibited.
Unplated	Prohibited.
Star	Prohibited for airborne use.
AN960	Use light or heavy series as required.
AN935 (light series)	Use where temperature will not exceed 400° F.
MS35337, MS35339	Use where temperature will exceed 400° F.

NOTE: AN935, MS35337, or MS35339 washers shall be used on all bolted bonding connections. Their function is to insure a tight connection with plain or self-locking nuts under conditions where thermal expansion of the bolt occurs.

(c) Bonding jumpers:

MS25083 Use where temperature does not exceed 300° F.

MS25083-3 (Quick disconnect) Prohibited for airborne applications.

(NOTE: MS25083-3 useful only in applications under 300° F)

High temperature type (to be designed by contractor) Use over 300° F.

(d) Clamps:

AN735 (cadmium plate) Use on corrosion-resistant steel plumbing where temperature does not exceed 300° F.

AN735 Use on aluminum plumbing only.

AN742 Not recommended due to tendency to loosen.

AN735 (zinc plate) Prohibited.

Cushion clamp Prohibited.

3.1.1.1.2 Hardware usage restrictions.- All cadmium-plated hardware shall be prohibited for space vehicle applications.

3.1.2 Jumpers.- Bonding jumpers (see 6.2.3) shall conform to MS25083 for thermal environments less than 300° F. The design of higher temperature jumpers will be approved by the procuring activity. All bonding jumpers shall be kept as short and direct as possible. The number of jumpers to be installed shall be kept to a minimum by careful design in conformance with the purpose of this specification. The use of two or more standard length jumpers, in series to provide the required overall length, will not be permitted without procuring activity approval.

3.1.3 Clamps.- Clamps shall be the plain type conforming to AN735. Non-standard clamps may be used only where standard clamps are not suitable and shall be subject to approval by the procuring activity.

3.1.4 Bonding surface preparation.- Surface preparation for an electrical bond (see 6.2.1) shall be accomplished by removing all anodic film, grease, paint, lacquer, or other high-resistance properties from the immediate area to insure reliable radio frequency (rf) impedance between adjacent metal parts. Abrasives which cause corrosion, if embedded in the metal, shall not be used. If abrasives or scrapers are used to remove any protective finish, they shall be of such a nature that produces a clean, smooth surface without removing excessive material under the protective finish. Chemical cleaning and surface preparation shall be in accordance with standard practice (see 3.4).

3.2 Classes of application.- Electrical bond classes of application shall be as specified in table I.

TABLE I. Electrical bond classes of application 1/

Class	Application	Reference paragraph
A	Antenna installation	3.3.1
C	Current path return	3.3.2
H	Shock hazard	3.3.3
L	Lightning protection	3.3.4
R	Rf potentials	3.3.5
S	Static charge	3.3.6

1/ Where a single bond is used to serve two or more classes of application, the design shall conform to the most critical requirement of bonding.

3.3 Design.-

3.3.1 Class A bonding (antenna installations).-

3.3.1.1 Impedance.- Radiating elements, exclusive of radar scanners and similar types where the counterpoise is actually part of the equipment, shall be installed and provided with an homogeneous counterpoise, or ground plane, of negligible impedance within the operating frequency ranges of the equipments involved, and shall be of adequate dimensions so as not to detract from the desired antenna radiation patterns.

3.3.1.2 Return path.- Antennas so designed that efficient operation depends on low resistance shall have the bond installed so that rf currents flowing on the external surface of a vehicle will have a low-impedance path of minimum length to the appropriate metal portion of the antenna.

3.3.1.3 Coaxial antenna.- Provisions shall be made for circumferential rf continuity between outer conductors of coaxial antenna transmission lines and ground planes of antennas.

3.3.2 Class C bonding (current path return).-

3.3.2.1 Current capacity.- The bond between equipment and vehicle structure shall be adequate to carry the power return current load. Table II shall be used as a guide.

3.3.2.2 Voltage drop.- The total impedance of wires, cables, and ground return paths shall be such that the voltage drop between the point of regulation and the load does not exceed the limits shown in table III. For current return leads of size AN-4(AWG-4), or larger wire, the bonding connection shall not be made directly to a structure but shall be made to a tab of sufficient size properly attached to the structure. For bonding leads smaller than the above, the methods shown on figures 1 through 5 shall be used.

3.3.2.3 Magnesium alloy structure.- Magnesium alloy structure shall not be used as a current path return.

3.3.2.4 Bonding in explosive fuel areas.- Bonding shall be provided in areas where hazardous conditions exist, due to the presence of explosive fuels and gasses, to prevent ignition in the event of power faults within the equipment. Resistance of fault-current bonding from equipment or component case to structure shall not exceed the values shown on figure 6 for each bond connection.

3.3.3 Class H bonding (shock hazard).-

3.3.3.1 Resistance.- Metallic conduit-carrying electrical wiring shall have a low-resistance bond of less than 0.1 ohm to structure at each terminating and break point. The bonding path may be through the equipment at which the conduit terminates.

3.3.3.2 Grounding.- Exposed conducting frames or parts of electrical or electronic equipment shall have a low-resistance bond of less than 0.1 ohm to structure. If the equipment design includes a ground terminal or pin which is internally connected to such exposed parts, a ground wire connection to such terminal or pin shall be provided. If compliance with 3.3.5.1 is necessary, owing to the nature of the equipment, the requirement of this paragraph will be considered to be met as well.

3.3.4 Class L bonding (lightning protection) (except for antenna systems).- Lightning protection shall be provided at all possible points of lightning entry into the aircraft. The entry points include but are not limited to the following:

- (a) Navigation lights
- (b) Fuel filler caps
- (c) Fuel gage covers
- (d) Refueling booms
- (e) Fuel vents
- (f) Antennas (see 6.3.1)

The following bonding requirements are designed to achieve protection against lightning discharge current carried between the extremities of an airborne vehicle without risk of damaging flight controls or producing sparking or voltages within the vehicle in excess of 500 volts. These requirements are based upon a lightning current waveform of 200,000 amperes peak, a width of 5 to 10 microseconds at the 90-percent point, not less than 20 microseconds width at the 50-percent point, and a rate of rise of at least 100,000 amperes per microseconds.

TABLE II. Current-carrying capacity of wires and cables

Wire or cable size		Continuous - duty current - amperes	
Aluminum	Copper	Single wire in free air	Wires and cables in conduit or bundles
	AW-22	—	5
	AW-20	11	7.5
	AW-18	16	10
	AW-16	22	13
	AW-14	32	17
	AW-12	41	23
	AW-10	55	33
	AW-8	73	46
	AW-6	101	60
	AW-4	135	80
	AW-2	181	100
	AW-1	211	125
	AW-0	245	150
	AW-00	283	175
	AW-000	328	200
	AW-0000	380	225
AL-8		60	36
AL-6		83	50
AL-4		108	66
AL-2		152	82
AL-1		174	105
AL-0		202	123
AL-00		235	145
AL-000		266	162
AL-0000		303	190

TABLE III. System voltages and allowable voltage drops

Nominal system voltage	Maximum allowable voltage drop	
	Equipment operation	
	Continuous	Intermittent
28	1	2
115	4	8
200	7	14

WIL-B-5087B(ASG)

BOLT SIZE:

BONDING NO. 6 AND NO. 8 SCREW WHERE EDGE DISTANCE WILL NOT PERMIT

NO. 10 SCREW

BONDING 3/16-INCH DIA MIN WHERE POSSIBLE

100-AMP CURRENT RETURN 1/4-INCH DIA MIN

200-AMP CURRENT RETURN 5/16-INCH DIA MIN

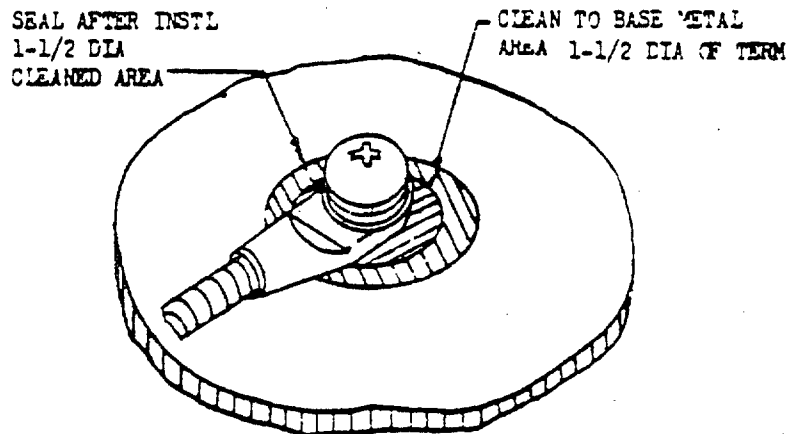
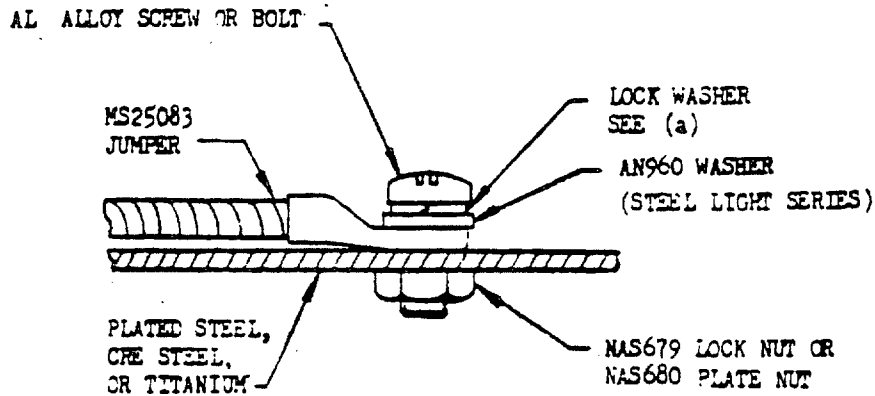

- (a) EITHER MS35337, MS35339, OR AN935 WASHERS SHALL BE USED, DEPENDING UPON DESIGN REQUIREMENTS.
- (b) LOCATION OF NUT OR HEAD OF BOLT IS OPTIONAL.
- (c) CLEAN AND SEAL IN ACCORDANCE WITH 6.4.
- (d) CORROSION PROTECTION SHALL BE AS SPECIFIED IN 3.4.5.

FIGURE 1. Typical bolted connection jumper to plated steel, corrosion-resistant steel, or titanium where max temp does not exceed 333° F

BOLT SIZES:

MIL-B-5087B(ASG)

BONDING 3/16-INCH DIA MIN
100-AMP CURRENT RETURN 1/4-INCH DIA MIN
200-AMP CURRENT RETURN 5/16-INCH DIA MIN

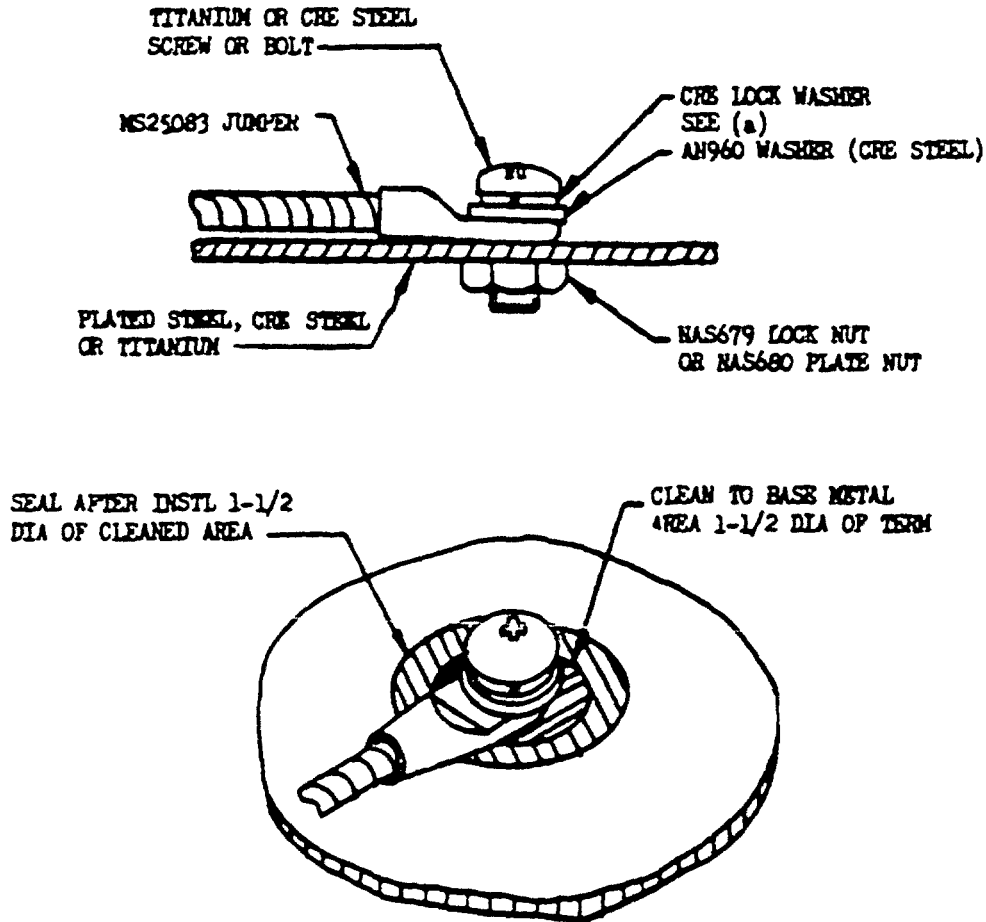

- (a) EITHER MS35337, MS35339, OR AN935 WASHERS SHALL BE USED, DEPENDING UPON DESIGN REQUIREMENTS.
- (b) NO SEALING REQUIRED WHERE MAXIMUM TEMPERATURE EXCEEDS 600° F.
- (c) LOCATION OF NUT OR HEAD OF BOLT IS OPTIONAL.
- (d) CLEAN AND SEAL IN ACCORDANCE WITH 6.4.
- (e) CORROSION PROTECTION SHALL BE AS SPECIFIED IN 3.4.5.

FIGURE 2. Typical bolted connection jumper to plated steel, corrosion-resistant steel or titanium where temperature exceeds 300° F

MIL-B-5082B(ASG)

BOLT SIZE:

BONDING NO. 6 AND NO. 8 SCREW WHERE EDGE
DISTANCE WILL NOT PERMIT
NO. 10 SCREW

BONDING 3/16-INCH DIA MIN WHERE
POSSIBLE

100-AMP RETURN 1/4-INCH DIA MIN
200-AMP RETURN 5/16-INCH DIA MIN

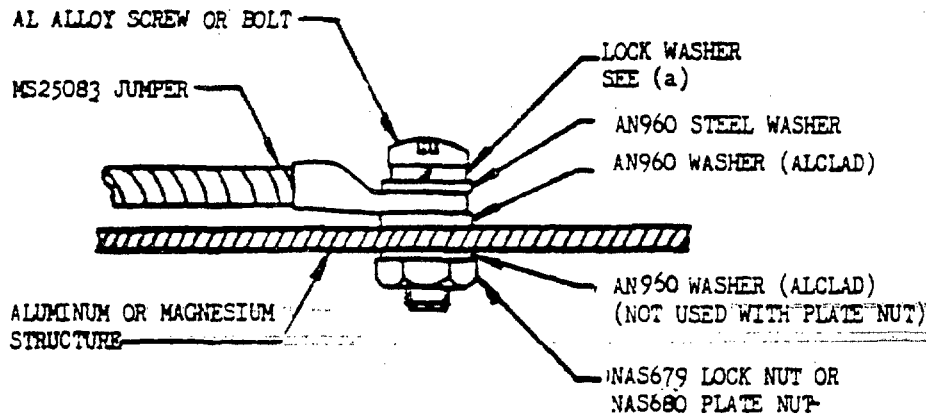

SEAL AFTER INSTL
1-1/2 DIA OF
CLEANED AREA

CLEAN TO BASIC METAL AREA
1-1/2 DIA OF WASHER

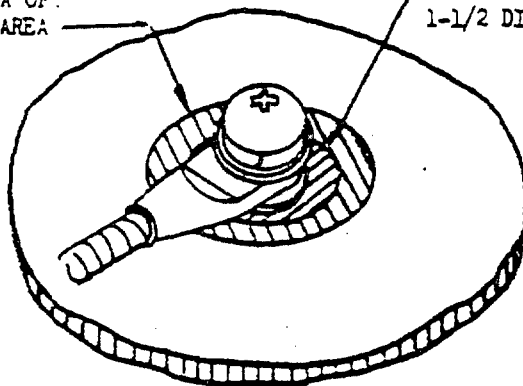

- (a) EITHER MS35337, MS35339, OR AN935 WASHERS SHALL BE USED, DEPENDING UPON DESIGN REQUIREMENTS.
- (b) ELECTRICAL BONDING TO MAGNESIUM ALLOY STRUCTURE FOR CURRENT RETURN IS PROHIBITED.
- (c) LOCATION OF NUT OR HEAD OF BOLT IS OPTIONAL.
- (d) CLEAN MATING SURFACE AND SEAL IN ACCORDANCE WITH 6.1.
- (e) CORROSION PROTECTION SHALL BE AS SPECIFIED IN 3.4.5.

FIGURE 3. Typical bolted connection jumper to aluminum or magnesium alloy structure where max temperature does not exceed 300° F

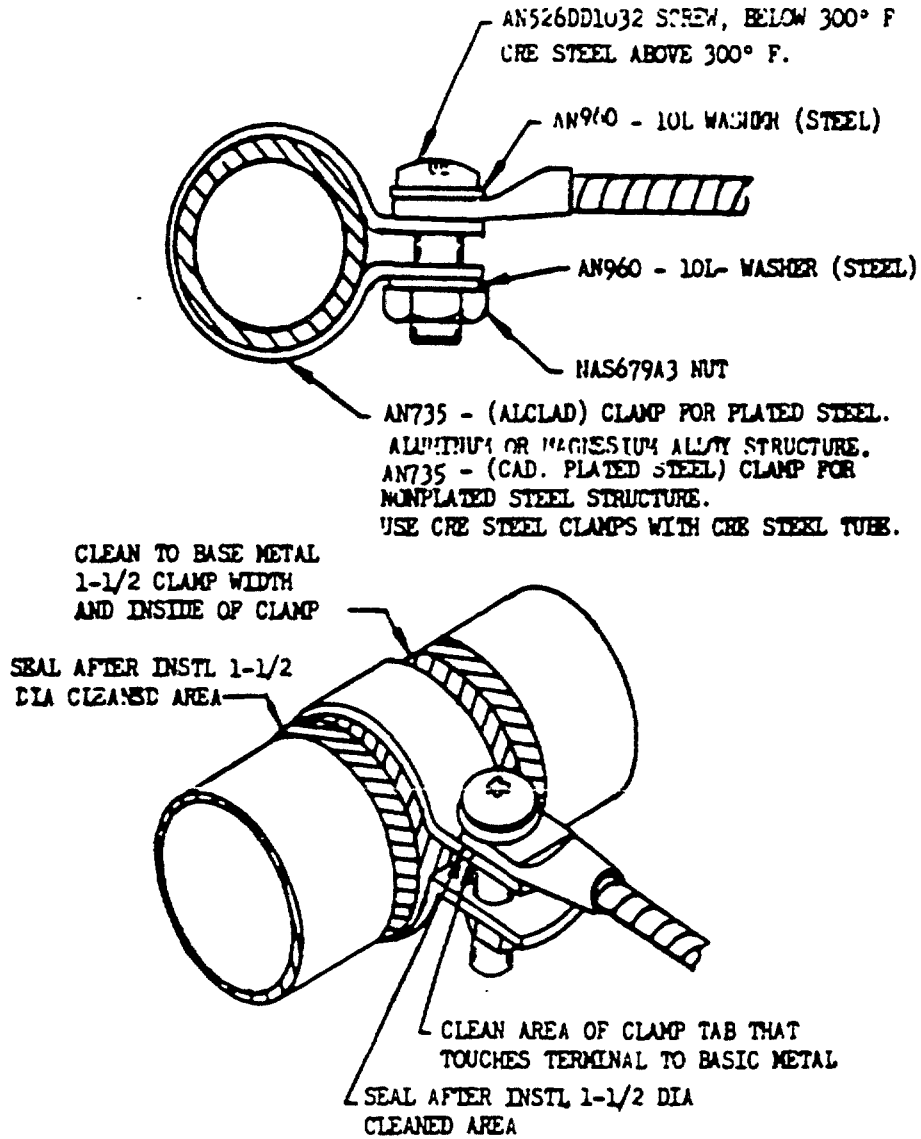

EITHER MS35337, MS35339, OR AN935 WASHERS SHALL BE USED,
DEPENDING UPON DESIGN REQUIREMENTS.
LOCATION OF NUT OR HEAD OF BOLT OPTIONAL.
CLEAN AND SEAL IN ACCORDANCE WITH 6.4.
CORROSION PROTECTION SHALL BE AS SPECIFIED IN 3.4.5.

FIGURE 4. Typical clamp connection -
jumper to tube

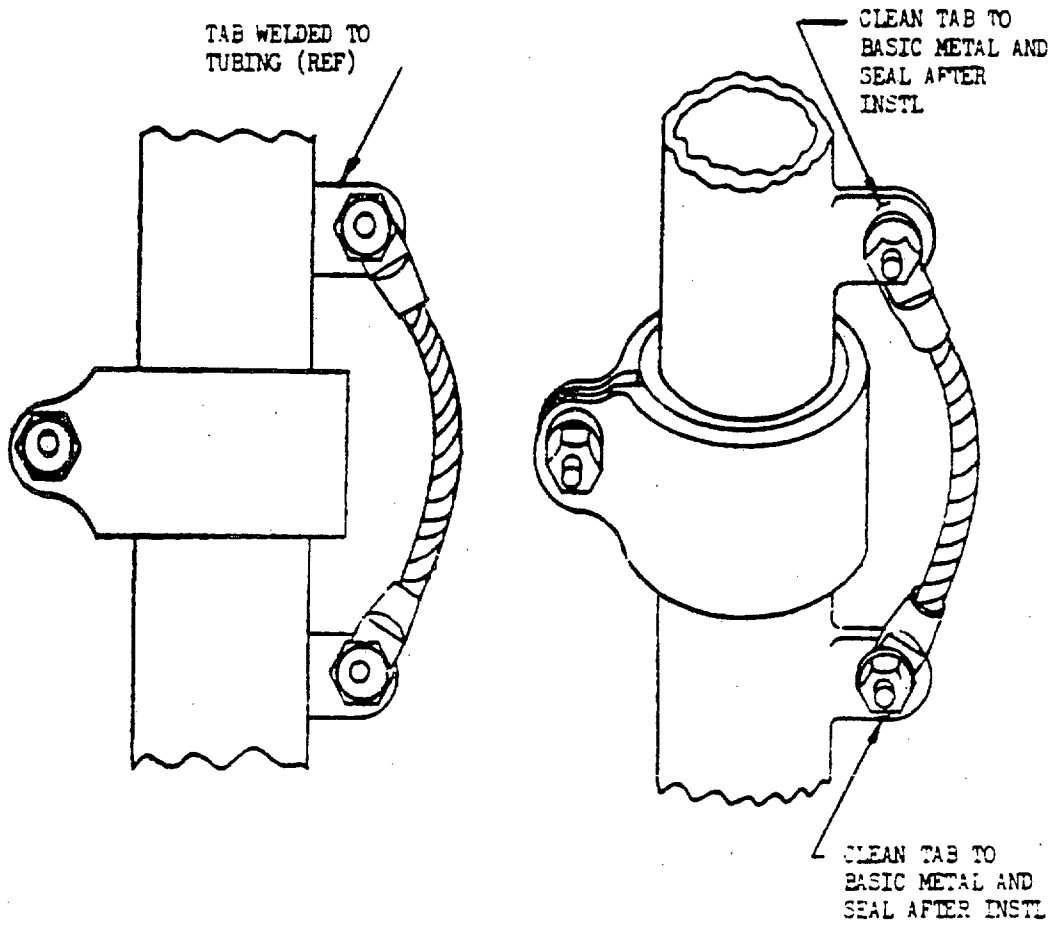

CLEAN MATING SURFACE AND SEAL IN ACCORDANCE WITH 6.4.
CORROSION PROTECTION SHALL BE AS SPECIFIED IN 3.4.5.

FIGURE 5. Typical method of bonding tubing across clamps

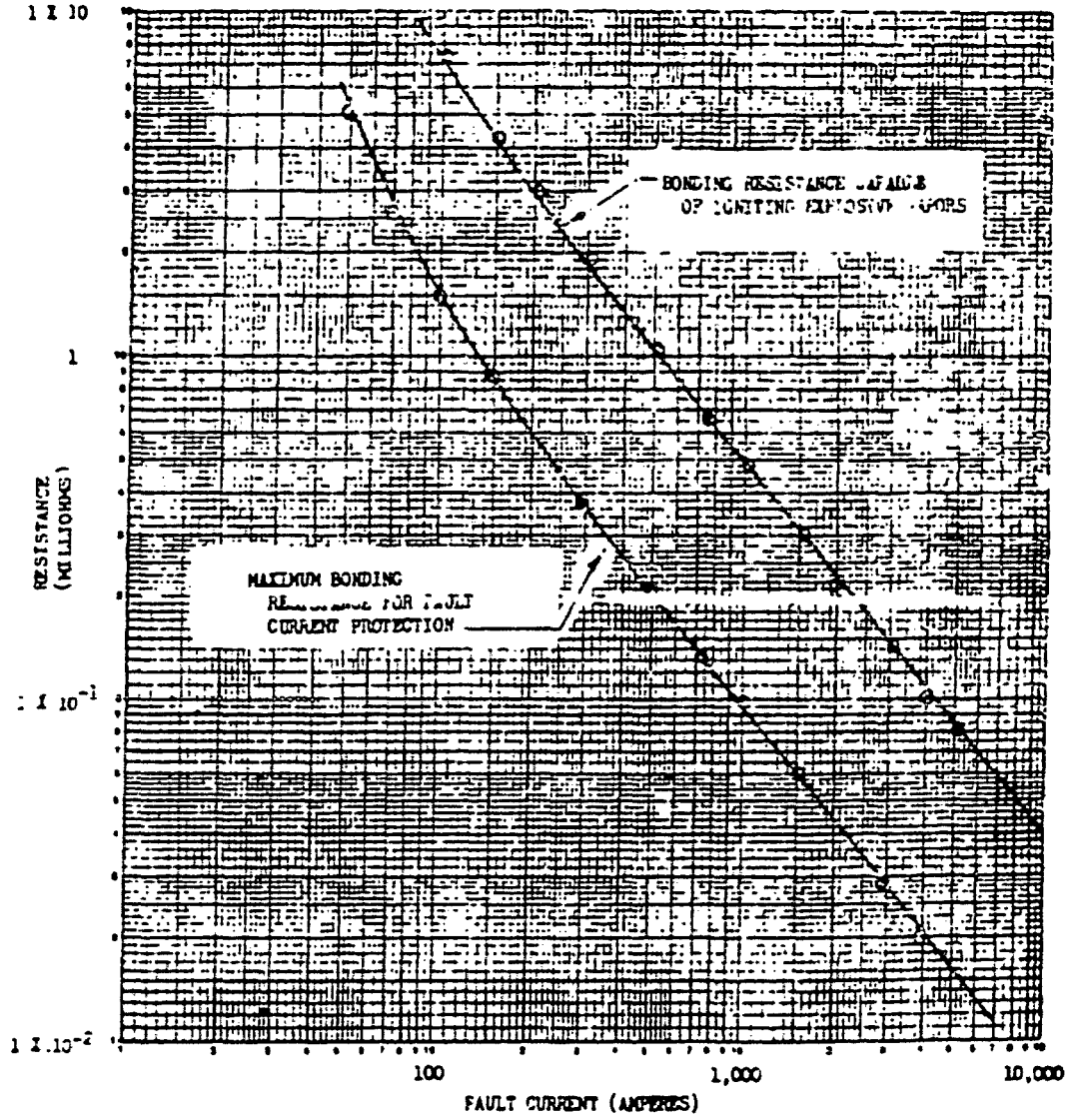

FIGURE 6. Fault current vs maximum allowed resistance for bonding between equipment and structure

3.3.4.1 Size of conductor.- Individual bonding jumpers for lightning protection shall be not less than No. 12 AWG for tinned stranded copper wire or No. 10 AWG for stranded aluminum wire. These wire sizes are valid only when a minimum of two jumpers are installed to carry the lightning current and when the jumpers are not subject to a direct arc. When the jumpers may be subject to arcing, substantially larger wire sizes 40,000 circular mils (AWG-4) minimum are required for protection against multiple strokes.

3.3.4.1.1 Soldered connections.- Soldered connections shall not be used on jumpers that are required to carry lightning currents. The method of attaching terminals to jumpers shall be verified by test.

3.3.4.2 Control surfaces.- Control surfaces and flaps shall have a bonding jumper across each hinge, except for installations having a single hinge in which case a minimum of two jumpers are required. Where necessary, additional jumpers shall be used between the control surface and structure to protect the control cables and levers so that the length of discharge path, through the control system, is at least 10 times the length of the path through the jumper or jumpers. A piano-type hinge may be considered as self-bonded, provided the resistance across the hinge is less than 0.01 ohm.

3.3.4.3 Protrusions bonding.- All external electrically isolated conducting objects, excluding antennas, which protrude above the vehicle surface shall have a bond to the vehicle skin or structure. Large nonconducting projections, essential to flight or housing personnel, such as vertical stabilizer parts, wing tips, astrodomes and canopies, shall have the lightning path externally distributed over their exposed area leading to the vehicle skin. Vehicle flight safety, flight characteristics, crew visibility, and equipment performance shall take precedence over these requirements. The conductive path shall not affect the structural integrity of the projection. Any conducting object, including personnel inside the protrusion, shall lie within the protective zone formed by the conductive path as illustrated and defined on figures 7 and 8. If a semiconducting surface or non-linear-graded surface resistance is used to initiate a lightning path, the voltage gradient at any point along the path to the skin shall be less than the breakdown gradient to any grounded object within, and the resistive path shall be at least 1 inch wide.

3.3.4.3.1 Bonding conductor restrictions.- Conductors shall be equal to, or larger than, 6,530 circular mils (AWG-12) for copper or 10,380 circular mils (AWG-10) for aluminum, where the conductor will not be subject to arcing. Where the conductor is subject to arcing, a minimum of 20,820 mils (AWG-7) for copper, or 33,100 mils (AWG-5) for aluminum, shall apply.

3.3.4.4 Riveted skin construction.- Close riveted skin construction which divides any lightning current over a number of rivets is considered adequate to provide a lightning discharge current path.

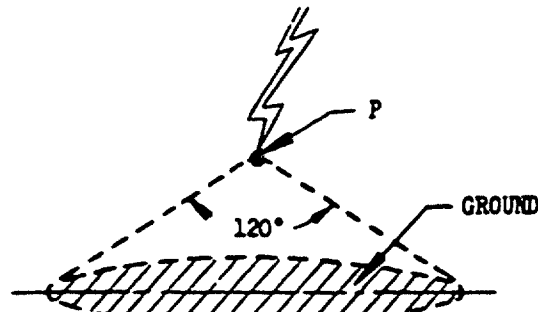

FIGURE 7-A. LIGHTNING PROTECTIVE ZONE CREATED BY A SINGLE CONDUCTIVE POINT, P, SUITABLY GROUNDED

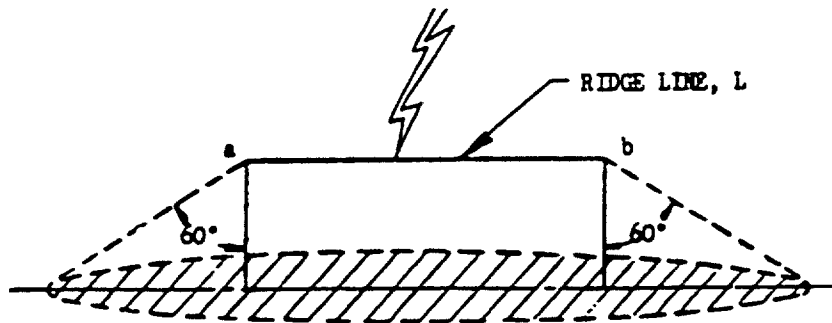

FIGURE 7-B. PROTECTIVE ZONE CREATED BY A CONDUCTIVE RIDGE LINE, L, SUITABLY GROUNDED. (THIS ZONE MAY BE CONSIDERED AS DEVELOPED BY A SIMPLE MOTION OF TRANSLATION OF THE CONE IN FIGURE 7-A FROM POINT a, TO POINT b, ABOVE)

DEFINITION

THE LIGHTNING PROTECTIVE ZONE MAY BE DEFINED GEOMETRICALLY AS THE SPACE OR AREA UNDER THE APEX OF AN IMAGINARY 120° CIRCULAR CONE; OR SUCH SPACE AS IS SWEEPED OUT BY ANY HYPOTHETICAL MOTION OF SUCH A CONE NORMAL TO ITS AXIS, WHEN EITHER THE APEX, OR THE RIDGE LINE DEVELOPED BY LATERAL MOTION THEREOF, IS CONSIDERED AS A CONDUCTIVE DISCHARGE POINT, OR EDGE, WHICH ACCORDINGLY IS DIRECTED AT THE LIGHTNING SOURCE AND MADE SUITABLY CONDUCTIVE TO THE CONE BASE, OR GROUND

NOTE: THIS FIGURE IS BASED ON THE ASSUMPTION THAT THE DIELECTRIC STRENGTH IS HIGH ENOUGH TO WITHSTAND THE VOLTAGE. THE DIELECTRIC STRENGTH SHOULD BE 100,000 VOLTS PER FOOT OF FLASHOVER PATH.

FIGURE 7. Typical protective zones

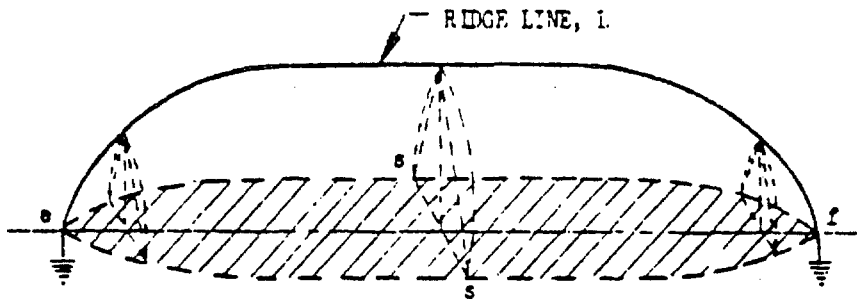

FIGURE 8-A. PROTECTIVE ZONE CREATED BY A SINGLE GROUNDED CONDUCTOR, L, LAID CENTRALLY OVER RIDGE OF TYPICAL DIELECTRIC CANOPY OR BLISTER. (THIS ZONE MAY BE CONSIDERED AS DEVELOPED BY A COMBINED RADIAL AND TRANSLATORY MOTION OF THE APEX, FROM e TO f)

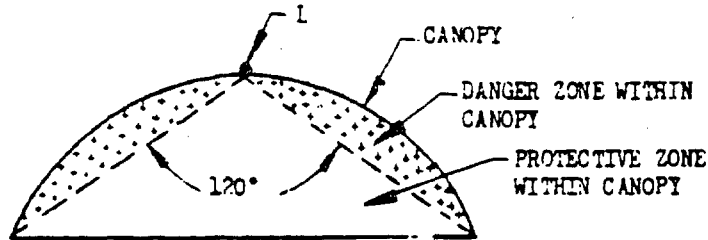

FIGURE 8-B. SECTIONAL VIEW TAKEN THROUGH FIGURE 8-A AT s-s SHOWING INADEQUATE PROTECTIVE ZONE CREATED WITHIN CANOPY WITH BUT A SINGLE CONDUCTOR, L, INSTALLED AS SHOWN HERE AND IN FIGURE 8-A.

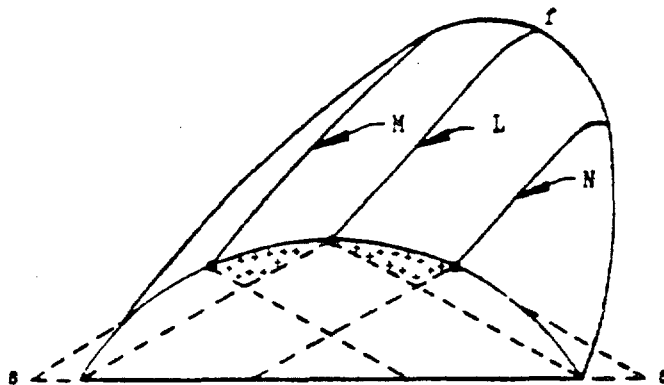

FIGURE 8-C. PERSPECTIVE OF SECTION s-f-s SHOWN IN FIGURES 8-A AND 8-B, SHOWING HOW A COMPOUND PROTECTIVE ZONE MAY BE BUILT UP BY INSTALLATION OF ADDITIONAL GROUNDED CONDUCTORS, M AND N, WHICH PRODUCE OVERLAPPING PROTECTIVE ZONES

NOTE: THIS FIGURE IS BASED ON THE ASSUMPTION THAT THE DIELECTRIC STRENGTH IS HIGH ENOUGH TO WITHSTAND THE VOLTAGE. THE DIELECTRIC STRENGTH SHOULD BE 100,000 VOLTS PER FOOT OF FLASHOVER PATH.

FIGURE 8. Canopy protective zones

3.3.4.5 Lightning protection tests.- Laboratory tests of lightning protection provisions for external sections, such as radomes and canopies, shall be performed to demonstrate adequate protection. The test waveform shall have a peak value of 200,000 amperes, a width of 5 to 10 microseconds at the 90-percent point, and not less than 20 microseconds width at the 50-percent point at the rate of rise of 100,000 amperes per microsecond. Discharges shall be fired at the test sample from all reasonable angles expected from lightning strikes.

3.3.4.6 Corrosion control.- When sealing techniques are used to control corrosion, tests shall be performed to demonstrate that lightning currents can be safely handled by the proposed sealing techniques. The waveform shall be as provided in 3.3.4.5.

3.3.5 Class R bonding (rf potentials).-

3.3.5.1 Grounding.- All electrical and electronic units or components which produce electromagnetic energy shall be installed to provide a continuous low-impedance path from the equipment enclosure to the structure. The contractor shall demonstrate by test that his proposed bonding method results in a direct current (dc) impedance of less than 2.5 milliohms from enclosure to structure. The bond from the equipment enclosure to the mounting plate furnished with the equipment shall comply also with these requirements, except that suitable jumpers may be used across any necessary vibration isolators.

3.3.5.2 Nearby conductors.- All conducting items having any linear dimension of 12 inches or more installed within 1 foot of unshielded transmitting antenna lead-ins shall have a bond to structure. Direct metal-to-metal contact is preferred. If a jumper is used, the jumper shall be as short as possible.

3.3.5.3 Vehicle skin.- Vehicle skin shall be so designed that a uniform low-impedance skin is produced through inherent rf bonding during construction. Rf bonding must be accomplished between all structural components comprising the vehicle, i.e., wings, fuselage, etc. Hatches, access doors, etc., not in the proximity of interference sources or wiring shall be either bonded to or permanently insulated from vehicle skin, except for the protective static bond. Consideration shall be given to the design to operational vibration and resultant breakdown of insulating finishes or intermittent electrical contact.

3.3.6 Class S bonding (static charge).- All isolated conducting items (except antennas) having any linear dimension greater than 3 inches, which are external to the vehicle, carry fluids in motion, or otherwise are subject to frictional charging, shall have a mechanically secure connection to the vehicle structure. The resistance of the connection shall be less than 1 ohm when dry.

3.3.7 Missile site bonding, grounding, and lightning protection criteria.-

3.3.7.1 Missile site grounding.- Grounding and bonding design for missile site installations must be determined specifically for each site. General techniques recommended for use at such sites are given in section 6. However, the overall requirements shall not necessarily be limited to the techniques listed.

3.3.7.2 Lightning protection for missile sites.- Lightning protection shall be provided at missile sites with each site considered on an individual basis according to the site requirements. Each phase of countdown and launch shall be considered so that all structures are protected. Underground sites shall be protected against strikes induced by the conductive trail left by the rising missile.

3.3.7.3 Missile site bonding.- Guidance for missile site bonding is provided in 6.3.7.

3.4 Methods.-

3.4.1 Bonding installations.- Bonding installations are considered as being permanent and inherently bonded when utilizing metal-to-metal joints by welding, brazing, sweating, or swaging. Insulating finishes need not be removed to comply with 3.1.4 if the resistance requirement is met without such removal. Examples of semi-permanent installations are:

- (a) Bare metal-to-metal joints of machined surfaces held together by thread-locking devices.
- (b) Riveted joints with a minimum of three rivets.
- (c) Tie rods.
- (d) Structural wires under tension.
- (e) Pinned fittings driven tight.
- (f) Normally permanent and immovable clamp fittings which have been assembled after all insulating finishes have been removed from the contact area.

3.4.2 Bonding connections.- Bonding connections shall be so installed that vibration, expansion, contraction, or relative movement incident to normal service use will not break or loosen the connection to such an extent that the resistance will vary during the movement. Bonding connections shall be located in a protected area, insofar as practicable, and whenever possible near a hand hole, inspection door, or other accessible locations to permit rapid inspection or replacement. The following conditions shall also apply:

- (a) Parts shall be bonded directly to the basic structure rather than through other bonded parts.
- (b) Shielded wire grounds shall be carried through the pins of a connector or attached directly to the basic structure. Bonding through the connector shells is permitted, provided the resistance through the shell is not greater than 2.5 milliohms.
- (c) Bonding jumpers shall be installed so that movable components are not impeded in their operation by the jumper.
- (d) Bonding connections shall not be compression fastened through nonmetallic materials.
- (e) Bonds on plumbing lines shall not be dependent on mounting clamps due to differential thermal expansion. Clamp and jumper assemblies shall be used. Cushion clamps shall not be used for bonding purposes.
- (f) Current returns and bonds, for avoidance of explosion hazards, shall be measured 100 percent.

3.4.3 Parts impractical to bond with jumpers.- The use of conductive epoxy resins is permitted, provided they conform to the performance requirements of this specification. When bonding by jumpers causes fouling or mechanical malfunction, other suitable means shall be employed which are in accordance with good engineering practice. Such means shall be subject to procuring activity approval.

3.4.4 Circular conductors.- Bonding of cylindrical or tubular conducting members, not inherently bonded, shall be accomplished by a plain clamp with a jumper. Bonding clamps, when required on flexible metallic conduit or hose, shall be so installed as not to crimp or damage the conduit or hose.

3.4.5 Dissimilar metals.- When joining dissimilar metals cannot be avoided, the jumpers and other elements of the bonding connection shall be selected to minimize the possibility of corrosion. If corrosion does occur, only replaceable hardware items, such as jumpers, bolts, nuts, washers, or separators, shall be affected rather than the basic structure. Washers shall not be surface treated or coated in any manner that will impair electrical conductivity. Unprotected, nonstainless steel shall not be used as a washer (see MS33586 for additional information). Figures 1 through 5 and 9 through 11 do not necessarily show the optimum combination of metals for all materials shown in the figures.

3.4.6 Refinishing.- When it has been necessary to remove any protective coating on metallic surfaces to conform with this specification, the completed assembly shall be refinished with its original finish or other suitable protective finish within 24 hours after inspection. In no case shall refinishing be delayed more than 7 days after removal of the finish. A clear lacquer conforming to MIL-L-6806 may be used if desired to facilitate subsequent inspection. When possible, Government inspection shall be accomplished before refinishing.

3.4.7 Intermittent electrical contact.- Intermittent electrical contact between conducting surfaces, which may become a part of a ground plane or a current path, shall be prevented either by bonding or by insulation if bonding is not necessary to conform to this specification.

3.4.8 Unapproved bonding methods.- Antifriction bearings, wire-mesh vibration cushion mounts, or lubricated bushings shall not be used as a bonding path. Piano hinges may not be used as a bonding path if a lubricant, dry-lube, or other nonconductive element is used in conjunction with the piano hinge.

4. QUALITY ASSURANCE PROVISIONS

4.1 Responsibility for inspection.- Unless otherwise specified in the contract or purchase order, the supplier is responsible for the performance of all inspection requirements as specified herein. Except as otherwise specified, the supplier may utilize his own facilities or any other commercial laboratory acceptable to the Government. The Government reserves the right to perform any of the inspections set forth in the specification where such inspections are deemed necessary to assure supplies and services conform to prescribed requirements.

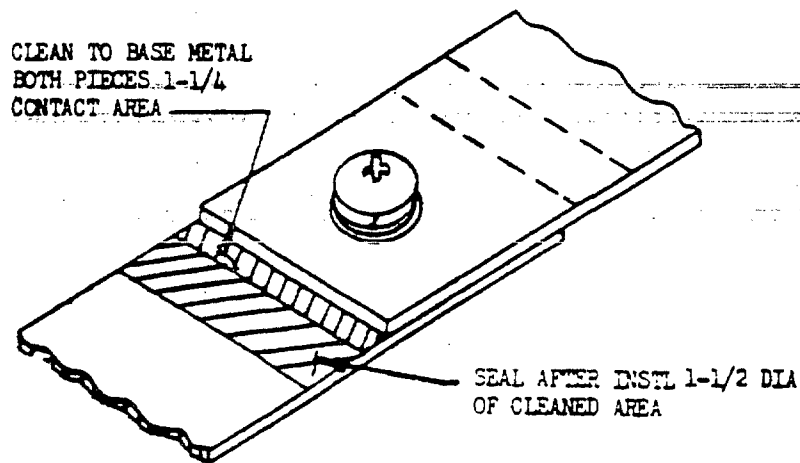
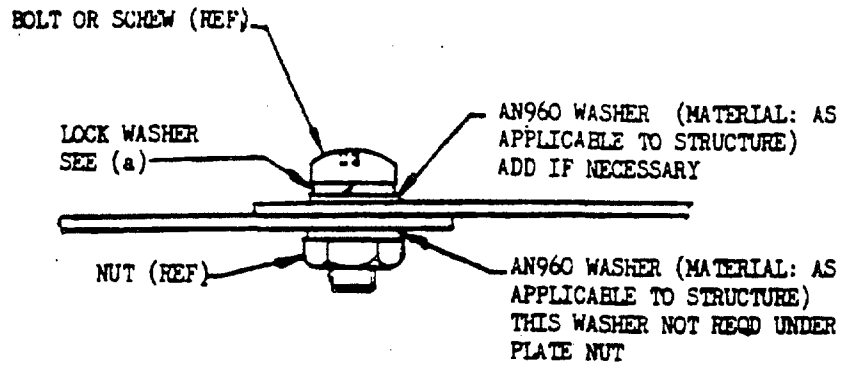

- (a) EITHER MS35337, MS35339, OR AN935 WASHERS SHALL BE USED, DEPENDING UPON DESIGN REQUIREMENTS.
- (b) DO NOT REMOVE FINISH FROM UNDER BOLT HEAD OR NUT.
- (c) CLEAN AND SEAL IN ACCORDANCE WITH 6.2.
- (d) CORROSION PROTECTION SHALL BE AS SPECIFIED IN 3.4.5.

FIGURE 9. Typical preparation of bonding connection in bolted structural joints

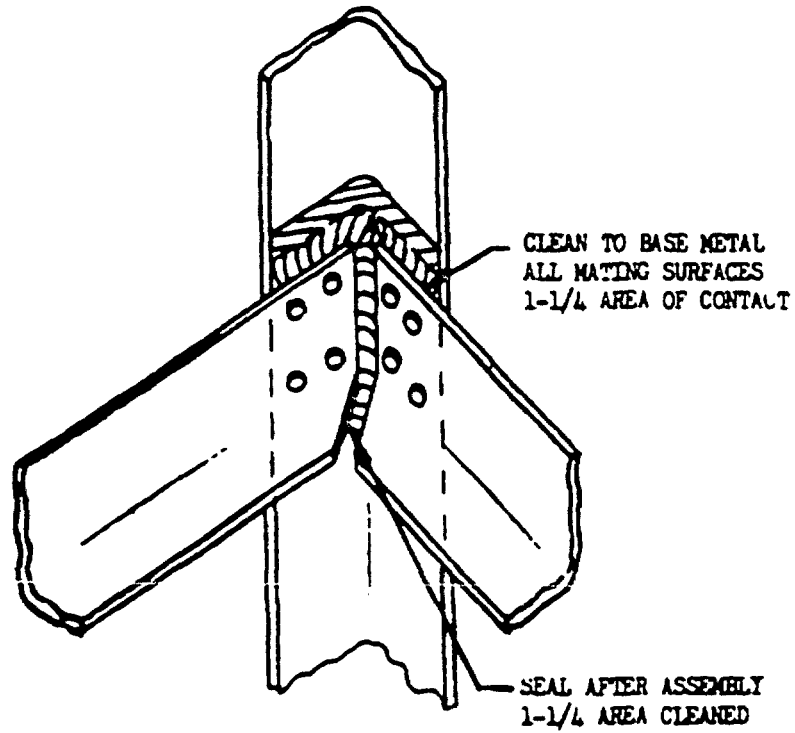

CLEAN MATING SURFACE AND SEAL IN ACCORDANCE
WITH 6.4.
CORROSION PROTECTION SHALL BE AS SPECIFIED IN 3.4.5.

FIGURE 10. Typical method of bonding between structural parts
in an assembly

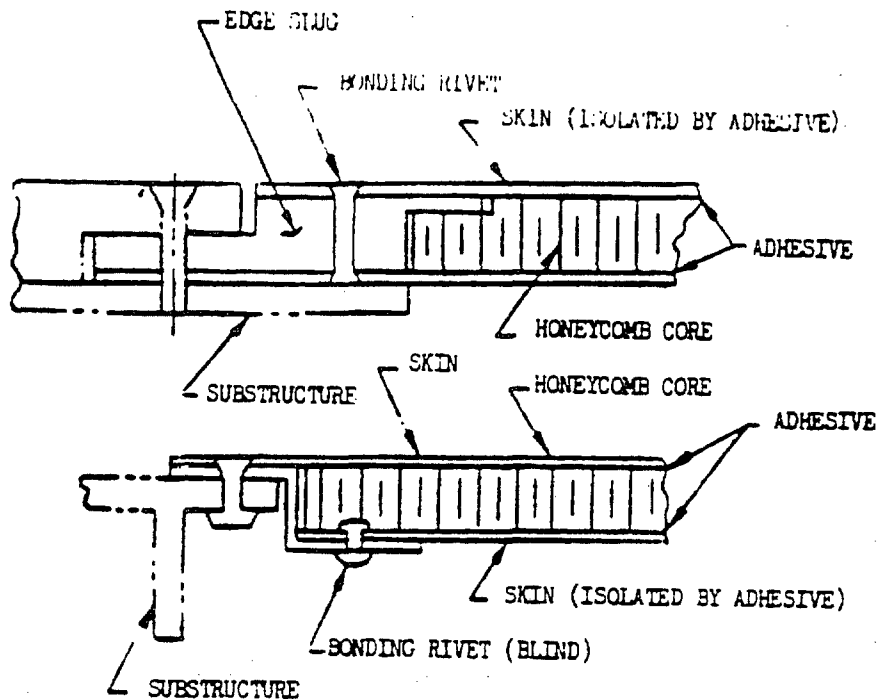

BOND ASSEMBLIES ISOLATED BY NONCONDUCTING PAINTING STRIPS TO THE SUBSTRUCTURE WITH RIVETS OR STEEL BOLTS.
 IN FUEL TANK AREAS, USE RIVETS, (RIV-O-SEAL NO. 860-615 -1/8) MADE BY THE FRANKLIN C. WOLFE CO., 3644 EASTMAN DRIVE, CULVER CITY, CALIFORNIA, OR EQUIVALENT.
 METAL DETAILS WHICH ARE COMPLETELY SHIELDED BY OTHER METAL PARTS WILL NOT REQUIRE ELECTRICAL BONDING.
 ALL RIVETS SHALL BE DRILLED FOR AND INSTALLED AFTER ADHESIVES ARE CURED.
 USE A MINIMUM OF THREE RIVETS (TOTAL AREA ELECTRICALLY EQUIVALENT TO THREE 1/8 DIA A17S RIVETS) FOR ANY ONE CONNECTION.
 THESE DIAGRAMS SHOW TYPICAL USE OF RIVETS FOR ELECTRICAL BONDING OF ADHESIVE ISOLATED DETAILS.
 CORROSION PROTECTION SHALL BE AS SPECIFIED IN 3.4.5.

FIGURE 11. Typical electrical bonding of details which are electrically isolated by adhesives

4.2 Resistance bonding.- Limited resistance measurements made as partial proof of satisfactory bonding shall be conducted on at least two vehicles representative of any particular model. Thereafter, additional measurements need be made only when a change in design or construction is introduced. Visual inspection shall be conducted on all vehicles to determine that no changes in methods or materials have been made that would affect conformance to this specification.

4.3 Refinishing.- Any part which has its finish damaged during the bonding tests shall be suitably refinished.

5. PREPARATION FOR DELIVERY

5.1 Not applicable to this specification.

6. NOTES

6.1 Intended use.- The bonding requirements and tests specified herein are intended to insure that the structures of aerospace systems are electrically stable and free from such hazards as lightning, static discharge and electrical shock, and to provide for the suppression of electromagnetic interference resulting from these hazards.

6.2 Definitions.- For the purpose of this specification, the following definitions are applicable.

6.2.1 Bond (noun).- A bond is any fixed union existing between two objects that results in electrical conductivity between the objects. Such union occurs either from physical contact between conductive surfaces of the objects or from the addition of a firm electrical connection between them.

6.2.2 Bonding or to bond.- Electrical bonding is defined as the means of obtaining the necessary electrical conductivity between units or unit and structure of the system or subsystem vehicle.

6.2.3 Bonding jumpers.- A bonding jumper is a braided wire or metal strap that provides the necessary electrical conductivity between the unit and vehicle structure which would otherwise not be in sufficient electrical contact.

6.2.4 Conducting surfaces or objects.- Conducting surfaces or objects include all objects having a resistivity of less than 1 megohm-centimeter.

6.2.5 Isolated surfaces or objects.- An isolated conducting object is one that is physically separated by intervening insulation from the vehicle structure and from other conductors which are bonded to the structure.

6.2.6 Detail equipment specification.- A detail equipment specification is defined as the document or documents which specify in detail the requirements of the weapon system, subsystem, or set.

6.3 Design objectives.- The following design objectives are recommended for application in Airborne installations.

6.3.1 Lightning protection for external antennas.- It is desired that external antennas be designed to avoid lightning currents entering the vehicle and causing damage to the vehicle or equipment installed. Such design may consist basically of a shunt spark-gap and a series capacitor in a suitable housing in accordance with MIL-A-9094.

6.3.2 Protection of antenna housing projections.- The protection of antenna housing structures imposes the additional requirement that the antenna function will not be adversely affected. The graded high-resistance path is indicated as one suitable means. A surface-conductor path, such as shown on figure 8-B or figure 8-C, may be broken by gaps to avoid effects on the antenna pattern. Gaps should not exceed 1/16 inch in length.

6.3.3 Protection of nonconducting projections.- Canopies may be considered as inherently protected if the flashover voltage from any point on the canopy along the surface to the vehicle skin is less than the puncture voltage through the canopy.

6.3.4 Movable canopies.- On movable canopies, similar to that on figure 8-C, lightning conductive paths need not be physically continuous but may terminate in not over a 1/4-inch gap to the vehicle skin. To avoid precipitation static effects, a spring contact providing a continuous path in the closed position is preferred.

6.3.5 Conductive paths.- Conductive paths should be designed to hold precipitation static effects to a minimum. This may be accomplished by bridging the conductor gaps or shielding the conductive path with semiconductor material.

6.3.6 Visibility.- If visibility requirements dictate, the lightning conductor path need not continue longitudinally to structure if a good connection can be made to a span-wise grounded member.

6.3.7 Missile site grounding.- The following techniques for bonding and grounding equipment at missile sites have been found satisfactory to overcome electromagnetic interference problems:

- (a) A good electrical ground reference is obtained by providing a ground grid matrix. The quantity and spacing of the driven ground rods should be as dictated by the requirements at each site.
- (b) All metallic structures, including cable trays, steel stanchions, structural platforms, etc., should be connected electrically to the ground grid. Steel reinforcement in concrete would normally not be grounded except for special cases.
- (c) Tie-points or stub-ups should be provided so that instrumentation and checkout equipment can be connected to the ground grid with an electrical lead of not more than 14 inches in length. Longer leads are useless for grounding and tend to introduce extraneous noise.

- (d) For protection against external rf interference, the shields of shielded cables should be grounded to equipment cases, or the facility ground, at each end and as many intermediate points as necessary. Instrument and audio grounds using the single-point ground concept for low-frequency protection should be carefully designed to operate in the rf environment at the site and should be compatible with the grounding system at the site.
- (e) Neutral and common terminals of the missile site power distribution system should be connected to the facility ground unless specific reasons dictate another method be used.

6.3.8 Missile and space vehicle bonding.- Missile and space vehicles create new and difficult electrical bonding problems in that ablative coatings, expanding joints, and other special techniques are involved. Each vehicle must be carefully studied to incorporate bonding techniques that will result in a satisfactory end product.

6.3.9 Lightning protection design criteria.- Studies have been conducted in lightning protection relative to the KC-135 and similar type aircraft. The results of this research appear in ASD Technical Note 61-92 and should be used as a guide in lightning protection design criteria.

6.4 Preparation of electrical mating surfaces.- The following procedures have been found satisfactory in the preparation of metals for electrical mating surfaces and are recommended for use by the contractor, as applicable, using Figures 1 through 5 and 9 through 11 as guides.

6.4.1 Grease, oil, or other nonconductive films should be removed with dry cleaning solvent in accordance with P-D-680.

6.4.2 Insoluble films should be removed by sanding and polishing with 7/0 garnet paper, using caution so as not to remove excessive metal. The area should be brushed clean.

6.4.3 After cleaning, the surfaces should be treated as follows.

6.4.3.1 Magnesium alloys.-

- (a) Wash the bare metal areas with a corrosion-protection solution conforming to type I of MIL-M-3171 for 1 minute, then rinse in clean water within 5 seconds. Dry thoroughly, reassemble the parts, and seal within 24 hours.
- (b) If paint finish has been removed and a paint finish is required on the final assembly, seal with the original finish.
- (c) If a paint finish is not required after reassembly, seal with a wipe-on, wipe-off sealant compound C-318 as made by Dow-Corning Corp., Midland, Michigan, or equivalent.

6.4.3.2 Aluminum alloys not subject to fuel exposure.- Aluminum alloys, not subject to exposure to fuels, should receive a brush coating of Iridite No. 11-2 conforming to MIL-C-5541 applied to the mating surfaces after polishing, then reassemble the parts. This should be followed by the procedure in 6.4.3.1(b) or 6.4.3.1(c), as applicable.

MIL-B-5087B(ASG)

6.4.3.3 Aluminum alloys subject to fuel exposure.- Aluminum alloys, subject to exposure to fuels, should receive a brush coating of Iridite No. 14-2 conforming to MIL-C-5541 applied to the mating surfaces after polishing, then reassemble the parts. After assembly, seal with sealant compound in accordance with MIL-S-8802.

Custodians:
Navy - WP
Air Force - (11)

Preparing activity:
Air Force - (11)

Reviewer activity:
Navy - WP
Air Force - (11)

User activity:
Army - KL

Review/user information is current as of the date of this document. For future coordination of changes to this document, draft circulation should be based on the information in the current Federal Supply Classification Listing of DoD Standardisation Documents.

STANDARDIZATION DOCUMENT IMPROVEMENT PROPOSAL

(See Instructions - Reverse Side)

1. DOCUMENT NUMBER

2. DOCUMENT TITLE

3a. NAME OF SUBMITTING ORGANIZATION

4. TYPE OF ORGANIZATION (Mark one)

VENDOR

USER

MANUFACTURER

OTHER (Specify): _____

3b. ADDRESS (Street, City, State, ZIP Code)

5. PROBLEM AREAS

a. Paragraph Number and Wording:

b. Recommended Wording:

c. Reason/Rationale for Recommendation:

6. REMARKS

7a. NAME OF SUBMITTER (Last, First, MI) - Optional

7b. WORK TELEPHONE NUMBER (Include Area Code) - Optional

8a. MAILING ADDRESS (Street, City, State, ZIP Code) - Optional

8b. DATE OF SUBMISSION (YYMMDD)

INSTRUCTIONS: In a continuing effort to make our standardization documents better, the DoD provides this form for use in submitting comments and suggestions for improvements. All users of military standardization documents are invited to provide suggestions. This form may be detached, folded along the lines indicated, taped along the loose edge (*DO NOT STAPLE*), and mailed. In block 5, be as specific as possible about particular problem areas such as wording which required interpretation, was too rigid, restrictive, loose, ambiguous, or was incompatible, and give proposed wording changes which would alleviate the problems. Enter in block 6 any remarks not related to a specific paragraph of the document. If block 7 is filled out, an acknowledgement will be mailed to you within 30 days to let you know that your comments were received and are being considered.

NOTE: This form may not be used to request copies of documents, nor to request waivers, deviations, or clarification of specification requirements on current contracts. Comments submitted on this form do not constitute or imply authorization to waive any portion of the referenced document(s) or to amend contractual requirements.

(Fold along this line)

(Fold along this line)

DEPARTMENT OF THE AIR FORCE



NO POSTAGE
NECESSARY
IF MAILED
IN THE
UNITED STATES

OFFICIAL BUSINESS
PENALTY FOR PRIVATE USE \$300

BUSINESS REPLY MAIL
FIRST CLASS PERMIT NO 73236 WASHINGTON D. C.

POSTAGE WILL BE PAID BY THE DEPARTMENT OF THE AIR FORCE

ASD/ENESS
Wright-Patterson AFB, OH 45433

